

CHONGQING KINGLONG MACHINERY CO.,LTD

Technical Sheet of HSZ-D

Model		HSZ0.5-D	HSZ1-D	HSZ1.5-D	HSZ2-D	HSZ3-D	HSZ5-D	HSZ10-D	HSZ15-D	HSZ20-D
Rated Capacity	t	0.5	1	1.5	2	3	5	10	15	20
Lifting Height	m	2.5	2.5	2.5	2.5	3	3	3	3	3
Test load	KN	6.3	12.5	20	25	40	63	125	200	250
Min distance Of hooks	mm	330	360	430	460	540	670	775	1000	1040
Pull power with rated load	N	240	250	265	335	340	365	380	400	415
Chain diameter	mm	5	6	7.1	8	7.1	9	9	10	10
Number of chain		1	1	1	1	2	2	4	6	8
Main Size	A	150	176.5	201	209	228	264	380	405	680
	B	129	152	173.5	176.5	173.5	188	188	228	222
	C	30	35	40	42	46	51	54	58	68
	D	150	174	201	213	201	236.5			
Net weight	kg	8.4	11.5	15.8	18.2	24.4	37.5	62.6	117	154
Packing size	cm	28x17.5x16 .5	30x20x18	36x23x20.5	37x24x21	36x26x20.5	48x34x21.5	59x50x27	70x65x36	77x70x36
Extra weight per 1m lifting height	kg	1.32	1.6	1.87	2.16	2.95	4.35	7.9	13.5	18.6

CHONGQING KINGLONG MACHINERY CO.,LTD

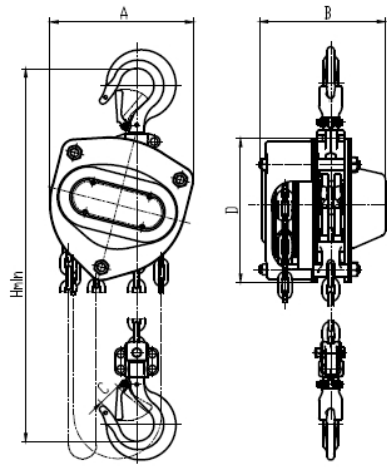

0.5t、1t、1.5t、2t

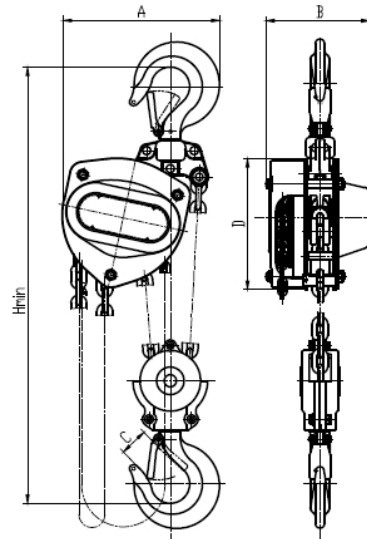

3t双链、5t

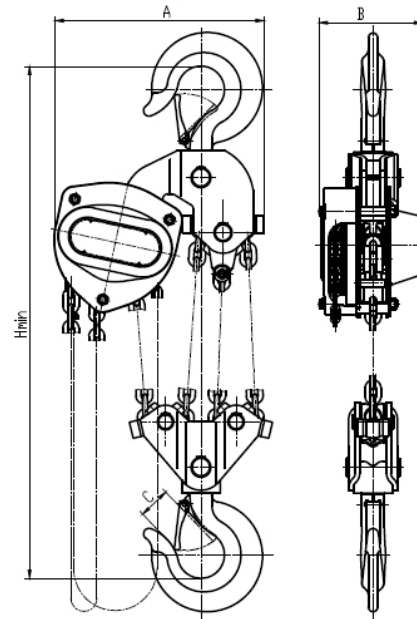

10t、15t

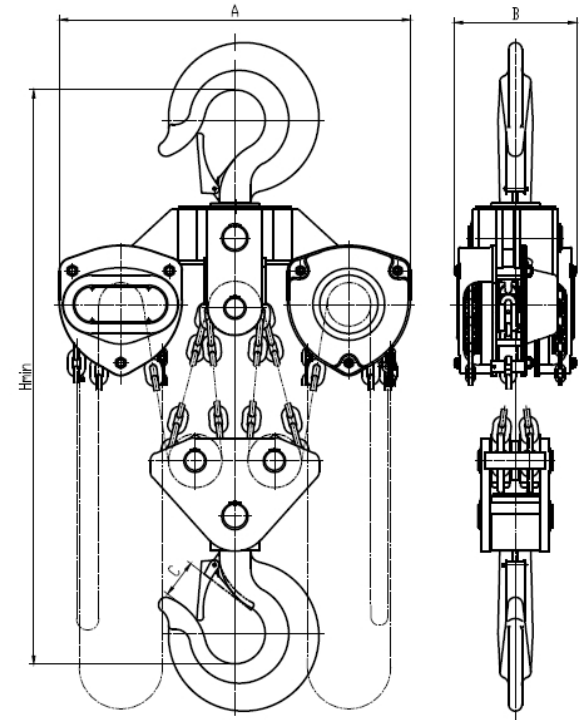

20t